

Motor Vehicle Claim Instructions

Repairer: Phone:

Your Vehicle Details:

Make, Model & Year: Rego:
Insured: Yes No If Yes, name of Insurer & Claim/Policy number:
Owner Name: MR/MRS/MS
Owner Address:
Owner Contact: Home/Work Mobile
Email: GST: Yes No ABN:
Date of Birth: License & Expiry Date:
Driver Name: MR/MRS/MS
Driver Address:
Driver Contact: Home/Work Mobile
Email:

Offending Vehicle Details:

Make, Model & Year: Rego:
Insured: Yes No If Yes, name of Insurer & Claim/Policy number:
Owner Name: MR/MRS/MS
Owner Address:
Owner Contact: Home/Work Mobile
Email:
Driver Name: MR/MRS/MS
Driver Address:
Driver Contact: Home/Work Mobile
Email:

Witness Details:

Name: MR/MRS/MS
Address:
Contact: Home/Work Mobile

Accident Details:

Date: Time: Place:
Description:
Police: Was matter reported to police? Yes No
Police Station: Name of Police Officer:

Diagram of Accident:



Your Vehicle



Other Vehicle



Stop Sign



Give Way Sign

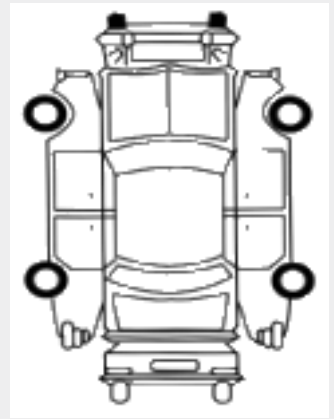

Shade damaged areas of your vehicle

WHAT YOU SHOULD DO

1. Before you sign this form, read the information on our website at www.elegal.com.au especially the Client Information Section under Motor Vehicle Collision Recovery. Contact us if you have any questions;
2. Complete the details on this form fully and truthfully. Provide as much information as possible;
3. Sign and return the form to us. Our address is on the first page;
4. Be prepared to provide us with a copy of the vehicle registration certificate and any other information about the collision
5. If you are comprehensively insured, lodge a claim form with your insurer marked "Report Only". This will protect your rights and will not affect your no claim bonus if a claim is not made;
6. Refer any communications from the offending party or their insurers to us. Do not communicate directly with these people.

WHAT WE WILL DO

1. Ensure that your vehicle is assessed by qualified assessors. There is no need for you to obtain any further quotes;
2. Make a claim on the offending party or their insurers. Upon recovery of funds, we will pay the repairer directly for the repair cost;
3. All costs and charges will be paid by the offending party or their insurance company. The repairer will also contribute to these costs and charges. **There will be no cost to you except in circumstances set out on www.elegal.com.au** – these include unless you deal directly with the offending party or their insurance company; withdraw your claim after 7 days of us contacting you to confirm these instructions or decide not to authorise the repairer to repair the vehicle.

Repairer Confirmation

(name of panel shop)

confirms that this matter is referred to E C Legal on the basis set out on our website at www.elegal.com.au under Motor Vehicle Collision Recovery – Repairer Information.

Dated:

Signature of Repairer:

E C Legal | LITIGATION
LAWYERS

Authority To Act

I / We instruct E C Legal to act on my / our behalf to recover the losses arising from the collision as set out on this form.

I / We authorise E C Legal to:

- do all things necessary for the conduct of the recovery action including settling the claim provided that the settlement covers all the costs arising from the collision and I have no further liability to any person;
- negotiate an agreeable cost of repairs directly with my referring repairer to enable a settlement to occur;
- commence legal proceedings (following any necessary advice from E C Legal) provided that my referring repairer and E C Legal are responsible for all costs incurred;
- pay your referring repairer and any other service providers (e.g. assessor, rental vehicle provider) directly for any expenses properly incurred

Dated:

Signature of Owner: